

**PART A**

FOR EACH OF THE FOLLOWING QUESTIONS IN PART A, ENTER THE MOST APPROPRIATE RESPONSE ON THE OMR SHEET.

A1. Which one of the following statements is correct? The electron volt (eV) is a unit of

- (E) (A) Electrostatic potential.  
 (B) Power.  
 (C) Electric charge.  
 (D) Electric field.  
 (E) Energy.

A2. The voltage supplied by wall sockets in Europe is twice as large as the voltage in Canada. If an electric hairdryer uses a power of 1200 W in Europe, what electric power would it use in Canada?

- (C) (A) 1200 W  
 (B) 600 W  
 (C) 300 W  
 (D) 1000 W  
 (E) 2400 W
- $$P_E = \frac{V_E^2}{R} \quad \therefore \frac{P_C}{P_E} = \frac{V_C^2}{V_E^2} = \frac{V_C^2}{(2V_C)^2} = \frac{1}{4}$$

$$P_C = \frac{V_C^2}{R} \quad \Rightarrow \quad P_C = \frac{P_E}{4} = \frac{1200 \text{ W}}{4} = 300 \text{ W}$$

$$V_E = 2 V_C$$

A3. A wire with resistance  $R$  is cut into two pieces of equal length and then the two pieces are connected in **parallel**. What is the resistance of the parallel wiring?

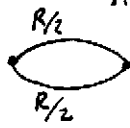
- (D) (A)  $R$   
 (B)  $R/2$   
 (C)  $2R$   
 (D)  $R/4$   
 (E)  $R^2$
- Since  $R = \rho \frac{l}{A}$  each half will have resistance  $R/2$
- 
- $$\frac{1}{R_p} = \frac{1}{R/2} + \frac{1}{R/2} = \frac{2}{R} + \frac{2}{R} = \frac{4}{R}$$

$$\Rightarrow R_p = R/4$$

A4. Which one of the following statements is correct?

- (A) (A) A magnetic south pole is near the northern geographic pole since it attracts magnetic north poles.  
 (B) A magnetic north pole is near the northern geographic pole since it attracts magnetic north poles.  
 (C) A magnetic north pole is near the northern geographic pole since it attracts magnetic south poles.  
 (D) A north magnetic pole coincides with the northern geographic pole.  
 (E) It is possible to isolate a magnetic south pole without an adjacent magnetic north pole.

A5. A positive charge which is initially moving towards the north enters a region where there is a magnetic field. It is observed to be deflected towards the East. In which direction does the magnetic field point?

- (B) (A) North  
 (B) Vertically up  
 (C) Vertically down  
 (D) East  
 (E) West

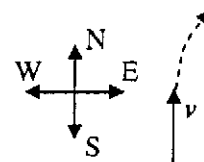

- A6. An electromagnetic wave consists of
- (B) (A) oscillating electric and magnetic fields which are parallel.
  - (B) (B) oscillating electric and magnetic fields which are mutually perpendicular.
  - (C) (C) an oscillating electric field with no magnetic field.
  - (D) (D) oscillating electric and magnetic fields which point in opposite directions.
  - (E) (E) an oscillating magnetic field with no electric field.

- A7. In a vacuum the velocity of an electromagnetic wave
- (E) (A) is zero.
  - (B) (B) depends on the wavelength of the wave.
  - (C) (C) is greater for light than it is for a radio wave.
  - (D) (D) is dependent on the wave's index of refraction.
  - (E) (E) is the same for all frequencies of electromagnetic waves.

- A8. Which one of the following statements concerning the index of refraction,  $n$ , for a material (not a vacuum) is true?
- (A) (A)  $n$  is always greater than 1.
  - (B) (B)  $n$  is always less than 1.
  - (C) (C)  $n$  may be negative.
  - (D) (D)  $n$  can be less than 1.
  - (E) (E)  $n$  can be equal to 1.

$$n = \frac{c}{v} \quad v < c \Rightarrow n > 1$$

- A9. Light, of wavelength  $\lambda$  when travelling in air, enters a piece of glass, with refractive index  $n = 1.50 = \frac{3}{2}$ , at an angle of incidence of  $\theta$ . In the glass the wavelength of the light is

- (D) (A)  $\lambda$ .
- (B) (B)  $\frac{3\lambda}{2}$ .
- (C) (C)  $\frac{3\lambda}{2} \sin \theta$ .
- (D) (D)  $\frac{2\lambda}{3}$ .
- (E) (E)  $\frac{2\lambda}{3} \sin \theta$ .

$$c = f\lambda$$

$$v_g = f\lambda_g$$

$$\therefore \frac{c}{v_g} = n = \frac{f\lambda}{f\lambda_g} = \frac{\lambda}{\lambda_g}$$

$$\Rightarrow \lambda_g = \frac{\lambda}{n} = \frac{2\lambda}{3}$$

- A10. A converging lens has a focal length of  $f$ . An object is placed on its principal axis at a distance of  $\frac{f}{2}$  from the lens. The image formed will be

- (E) (A) real, inverted and smaller than the object.
- (B) (B) real, upright and larger than the object.
- (C) (C) virtual, inverted and smaller than the object.
- (D) (D) virtual, upright and smaller than the object.
- (E) (E) virtual, upright and larger than the object.

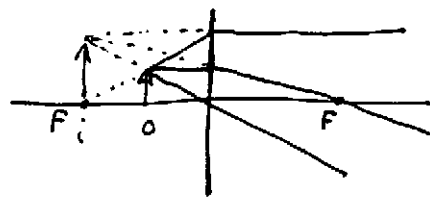

**PART B**

FOR EACH OF THE FOLLOWING PROBLEMS, B1 TO B5, ON PAGES 4 TO 6, WORK OUT THE SOLUTION IN THE SPACE PROVIDED AND ENTER YOUR ANSWERS ON PAGE 6.

ONLY THE ANSWERS WILL BE MARKED. THE SOLUTIONS WILL NOT BE MARKED.

- B1. Two point charges,  $q_1 = +4.00 \times 10^{-6} \text{ C}$  and  $q_2 = +6.00 \times 10^{-6} \text{ C}$ , are placed 0.800 m apart. Calculate the absolute electrostatic potential at point P midway between the two charges.

$$\begin{aligned} V_P &= V_1 + V_2 \\ &= \frac{kq_1}{r_1} + \frac{kq_2}{r_2} \quad , \quad r_1 = r_2 = \frac{r}{2} \\ &= \frac{kq_1}{r/2} + \frac{kq_2}{r/2} \\ &= \frac{2k}{r} (q_1 + q_2) \\ &= \frac{2(9.00 \times 10^9 \text{ N}\cdot\text{m}^2/\text{C}^2) (4.00 \times 10^{-6} \text{ C} + 6.00 \times 10^{-6} \text{ C})}{(0.800 \text{ m})} \\ &= 2.25 \times 10^5 \text{ V} \end{aligned}$$

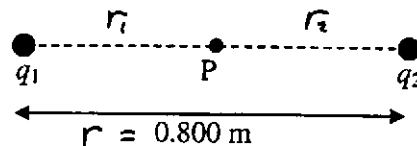

- B2. An electric heater with resistance  $8.80 \Omega$  is connected to an AC voltage supply and delivers heat with a power of 1.50 kW. Calculate the peak voltage of the AC voltage supply.

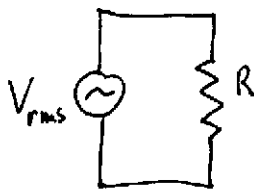

$$\begin{aligned} P &= \frac{V_{\text{rms}}^2}{R} \\ \Rightarrow V_{\text{rms}} &= \sqrt{PR} = \frac{V_0}{\sqrt{2}} \\ \Rightarrow V_0 &= \sqrt{2PR} \\ &= \sqrt{2(1.50 \times 10^3 \text{ W})(8.80 \Omega)} \\ &= 162 \text{ V} \end{aligned}$$

continued on page 5 ...

- B3. The force on a charged particle moving with velocity  $2.08 \times 10^5$  m/s at an angle of  $70.0^\circ$  to the direction of a magnetic field of 0.216 T is  $7.86 \times 10^{-4}$  N. Calculate the magnitude of the charge on the particle.

$$\begin{aligned} F &= q v B \sin \theta \\ \Rightarrow q &= \frac{F}{v B \sin \theta} \\ &= \frac{7.86 \times 10^{-4} \text{ N}}{(2.08 \times 10^5 \text{ m/s})(0.216 \text{ T})(\sin 70.0^\circ)} \\ &= 1.86 \times 10^{-8} \text{ C} \end{aligned}$$

- B4. Calculate the wavelength of a radio wave, travelling in a vacuum, with frequency 95.0 MHz.

$$\begin{aligned} c &= f \lambda \\ \Rightarrow \lambda &= \frac{c}{f} \\ &= \frac{3.00 \times 10^8 \text{ m/s}}{95.0 \times 10^6 \text{ s}^{-1}} \\ &= 3.16 \text{ m} \end{aligned}$$

continued on page 6 ...

- B5. A diamond, with index of refraction 2.42, is submerged in benzene, with index of refraction 1.50. Calculate the critical angle for total internal reflection of light travelling in the diamond and striking the diamond-benzene interface.

$$\begin{aligned}n_1 \sin \theta_1 &= n_2 \sin \theta_2 \\ \Rightarrow n_1 \sin \theta_c &= n_2 \sin 90^\circ \\ &= n_2 \\ \Rightarrow \sin \theta_c &= \frac{n_2}{n_1} \\ &= \frac{1.50}{2.42} \\ \Rightarrow \theta_c &= 38.3^\circ\end{aligned}$$

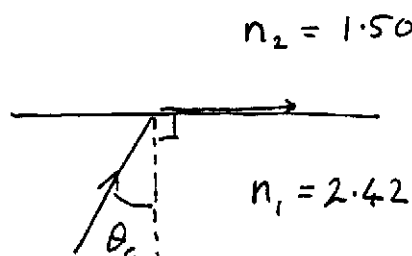

**ANSWERS FOR PART B**

ENTER THE ANSWERS FOR THE PART B PROBLEMS IN THE BOXES BELOW.

THE ANSWERS MUST CONTAIN THREE SIGNIFICANT FIGURES AND THE UNITS MUST BE GIVEN.

ONLY THE ANSWERS WILL BE MARKED. THE SOLUTIONS WILL NOT BE MARKED.

B1

B2

B3

B4

B5

continued on page 7 ...

**PART C**

IN EACH OF THE PART C QUESTIONS ON THE FOLLOWING PAGES, GIVE THE COMPLETE SOLUTION AND ENTER THE FINAL ANSWER IN THE BOX PROVIDED.

THE ANSWERS MUST CONTAIN THREE SIGNIFICANT FIGURES AND THE UNITS MUST BE GIVEN.

**SHOW YOUR WORK** – NO CREDIT WILL BE GIVEN FOR ANSWERS ONLY. EQUATIONS NOT PROVIDED ON THE FORMULAE SHEET MUST BE DERIVED.

USE THE BACK OF THE PREVIOUS PAGE FOR YOUR ROUGH WORK.

- C1. The emf of a real battery is 12.0 V. The battery is connected to two resistors,  $R_1 = 120 \Omega$  and  $R_2 = 60.0 \Omega$  connected in **parallel**. A current of  $I = 0.290 \text{ A}$  flows through the battery.

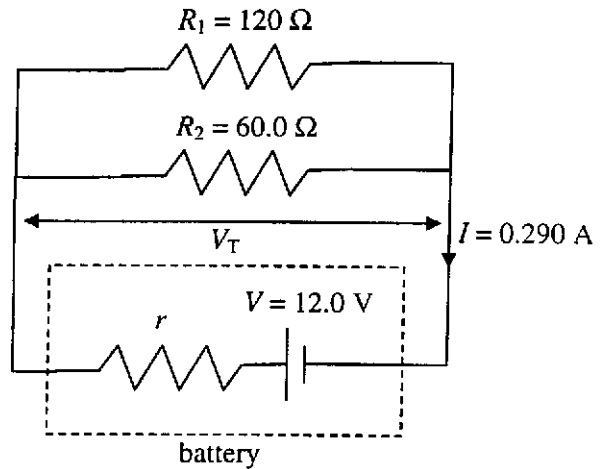

- (a) Calculate the equivalent resistance of  $R_1$  and  $R_2$  in parallel.

$$40.0 \Omega$$

$$\frac{1}{R_p} = \frac{1}{R_1} + \frac{1}{R_2} = \frac{1}{120 \Omega} + \frac{1}{60.0 \Omega}$$

$$\Rightarrow R_p = 40.0 \Omega$$

- (b) Calculate the terminal voltage  $V_T$  of the battery when the current  $I$  flows in the circuit.

$$11.6 \text{ V}$$

Equivalent circuit

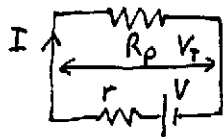

$$\begin{aligned} V_T &= I R_p \\ &= (0.290 \text{ A})(40.0 \Omega) \\ &= 11.6 \text{ V} \end{aligned}$$

- (c) Calculate the internal resistance,  $r$ , of the battery.

$$1.38 \Omega$$

$$\begin{aligned} V_T &= V - I r \\ \Rightarrow r &= \frac{V - V_T}{I} = \frac{12.0 \text{ V} - 11.6 \text{ V}}{0.290 \text{ A}} = 1.38 \Omega \end{aligned}$$

$$\begin{aligned} \text{OR} \quad V &= I(r + R_p) \\ \Rightarrow r &= \frac{V}{I} - R_p = \frac{12.0 \text{ V}}{0.290 \text{ A}} - 40.0 \Omega = 1.38 \Omega \end{aligned}$$

continued on page 8 ...

C2. A TV set uses a potential difference of 240 V to accelerate electrons towards the screen. To reach all points on the screen the electrons must be forced on a curved path with a magnetic field. The mass of an electron is  $9.11 \times 10^{-31}$  kg.

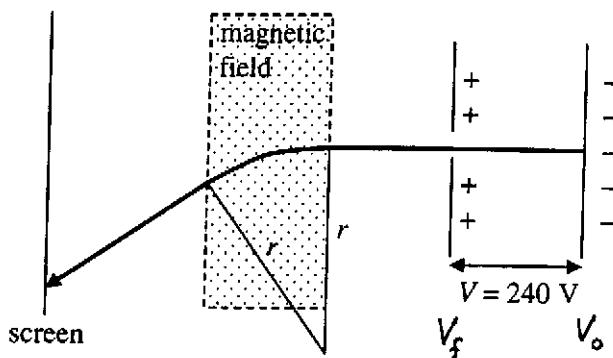

- (a) Calculate the speed of the electrons after acceleration through the potential difference  $V$ . Assume the electrons start from rest.

$$\begin{aligned}
 KE_0 + eV_0 &= KE_f + eV_f && \boxed{9.18 \times 10^6 \text{ m/s}} \\
 \Rightarrow 0 - eV_0 &= \frac{1}{2}mv^2 - eV_f \\
 \Rightarrow \frac{1}{2}mv^2 &= e(V_f - V_0) = eV \\
 \Rightarrow v &= \sqrt{\frac{2eV}{m}} = \sqrt{\frac{2(1.60 \times 10^{-19} \text{ C})(240 \text{ V})}{9.11 \times 10^{-31} \text{ kg}}} \\
 &= 9.18 \times 10^6 \text{ m/s}
 \end{aligned}$$

- (b) Calculate the magnitude of the magnetic field needed to force the electrons onto a curved path with radius  $r = 5.50$  cm. Assume the magnetic field is uniform and perpendicular to the velocity of the electrons. (If you did not get an answer for (a) use a speed of  $8.50 \times 10^6$  m/s.)

$$\begin{aligned}
 F &= ma_c && \boxed{9.50 \times 10^{-4} \text{ T}} \\
 \Rightarrow qvB \sin 90^\circ &= m \frac{v^2}{r} \\
 \Rightarrow eB &= \frac{mv}{r} \\
 \Rightarrow B &= \frac{mv}{er} = \frac{(9.11 \times 10^{-31} \text{ kg})(9.18 \times 10^6 \text{ m/s})}{(1.60 \times 10^{-19} \text{ C})(5.50 \times 10^{-2} \text{ m})} \\
 &= 9.50 \times 10^{-4} \text{ T}
 \end{aligned}$$

C3. An object is placed on the principal axis of a converging lens with focal length 204 mm. The image produced is inverted and is exactly twice as large as the object.

- (a) Find an expression for the image distance,  $d_i$ , in terms of the object distance,  $d_o$ , for this situation.

$$m = \frac{h_i}{h_o} = -\frac{d_i}{d_o}, \quad h_i = -2h_o$$

$$\Rightarrow -\frac{2h_o}{h_o} = -\frac{d_i}{d_o} \Rightarrow d_i = 2d_o$$

$$d_i = 2d_o$$

- (b) Calculate the object distance,  $d_o$ .

$$\frac{1}{f} = \frac{1}{d_i} + \frac{1}{d_o} = \frac{1}{2d_o} + \frac{1}{d_o}$$

$$\Rightarrow \frac{1}{f} = \frac{3}{2d_o}$$

$$\Rightarrow d_o = \frac{3f}{2} = \frac{3(204 \text{ mm})}{2} = 306 \text{ mm}$$

$$306 \text{ mm}$$

- (c) Calculate the image distance  $d_i$ .

$$\begin{aligned} d_i &= 2d_o \\ &= 2(306 \text{ mm}) \\ &= 612 \text{ mm} \end{aligned}$$

$$612 \text{ mm}$$

- (d) On the figure below sketch a ray diagram for this situation. Show at least two rays from the object to the image.

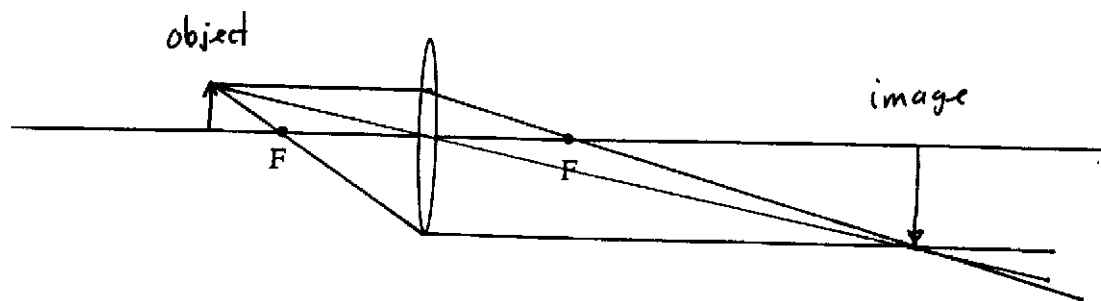

**END OF EXAMINATION**