

UNIVERSITY OF SASKATCHEWAN
Department of Physics and Engineering Physics

Physics 111.6
MIDTERM TEST #1

October 11, 2007

Time: 90 minutes

NAME: MASTER
 (Last) Please Print (Given)

STUDENT NO.: _____

LECTURE SECTION (please check):

- 01 Dr. A. Robinson
- 02 B. Zulkoskey
- 03 Dr. C. Mitchell
- 97 M. Lepage
- C15 F. Dean

INSTRUCTIONS:

1. You should have a test paper, a formula sheet, and an OMR sheet. The test paper consists of 9 pages. **It is the responsibility of the student to check that the test paper is complete.**
2. Enter your name and STUDENT NUMBER on the OMR sheet.
3. The test paper, the formula sheet and the OMR sheet must all be submitted.
4. The test paper will be returned. The formula sheet and the OMR sheet will NOT be returned.

PLEASE DO NOT WRITE ANYTHING ON THIS TABLE

QUESTION NO.	MAXIMUM MARKS	MARKS OBTAINED
Part A	10	
Part B	10	
C1	5	
C2	5	
C3	5	
TOTAL	35	

continued on page 2...

PART A

FOR EACH OF THE FOLLOWING QUESTIONS IN PART A, ENTER THE MOST APPROPRIATE RESPONSE ON THE OMR SHEET.

$$V_1 = \frac{4}{3}\pi r^3$$

$$V_2 = \frac{4}{3}\pi (2r)^3$$

$$V_2 = 8\left(\frac{4}{3}\pi r^3\right)$$

$$V_2 = 8V_1$$

- A1. By what factor does the volume of a spherical balloon increase if its radius is doubled?
 C (A) 2 (B) 4 (C) 8 (D) 8/3 (E) $\sqrt[3]{2}$

- A2. Given the dimensions of the symbols shown in the table, which one of the following options correctly gives the dimensions of $E = \frac{1}{2}mv^2$?
 D

m	$[M]$
v	$[L][T]^{-1}$

$$[E] = [M]([L][T^{-1}])^2$$

$$[E] = [M][L]^2[T]^{-2}$$

- (A) $[M][L]^2[T]^2$ (B) $[M]^2[L]^2[T]^{-2}$ (C) $[M][L][T]^4$
 (D) $[M][L]^2[T]^{-2}$ (E) $[M][L]^2[T]^{-3}$

- A3. A vector B has x and y components B_x and B_y . Assume that B_x and B_y both have nonzero magnitudes. Which one of the following statements is **NOT** correct?

$$B = \sqrt{B_x^2 + B_y^2}$$

- C (A) The magnitude of B is greater than the magnitude of B_x . T
 (B) The magnitude of B is greater than the magnitude of B_y . T
 (C) The magnitude of B is equal to the sum of the magnitudes of B_x and B_y . F $\neq B_x + B_y$
 (D) B_x and B_y are at right angles to each other. T
 (E) Given B_x and B_y , we can find the angle that B makes with the x -direction. T

- A4. A toy rocket is propelled straight upward from the ground and reaches a height Δy . After an elapsed time Δt , measured from the time the rocket was launched, the rocket has fallen back down to the ground, landing at the same spot from which it was launched. The magnitude of the average velocity of the rocket during this time is
 A

- (A) 0 (B) $2\frac{\Delta y}{\Delta t}$ (C) $\frac{\Delta y}{\Delta t}$ (D) $4\frac{\Delta y}{\Delta t}$ (E) $\frac{1}{2}\frac{\Delta y}{\Delta t}$

displacement is zero.

- A5. A soccer player kicks the ball up the field. The x direction is taken as parallel to the ground, and the y direction as perpendicular to the ground. The ball takes off with an angle of 30° with respect to the ground. Air resistance may be neglected. Which one of the following statements is **NOT** correct?
 D

- (A) The ball has a zero acceleration component in the x direction. T
 (B) The ball has a zero velocity component in the y direction at the top of its trajectory. T
 (C) The ball has a constant acceleration component in the y direction. T
 (D) The ball has a zero acceleration component in the y direction at the top of its trajectory. F
 (E) The ball has a constant velocity in the x direction. T

$\vec{a} = 9.80 \text{ m/s}^2$ downward while the ball is in the air.

A6. Examine the velocity-time graph. Which one of the statements below is **NOT** correct?

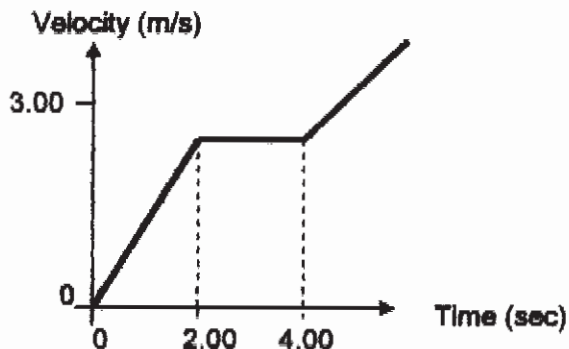

C

- (A) The tangent to the velocity-time curve gives the instantaneous acceleration. T
- (B) The acceleration is constant and non-zero between $t = 0$ s and $t = 2.00$ s. T
- (C) The object is stationary between $t = 2.00$ s and $t = 4.00$ s. F
- (D) The velocity of the object increases after $t = 4.00$ s. T
- (E) The object starts from rest. T

velocity is constant
 b/w $t = 2.00$ s and $t = 4.00$ s

A7. Which one of the following statements describes an object undergoing a negative acceleration?

B

- (A) An object moves in the positive direction and its speed is increasing. $a +ve$
- (B) An object moves in the negative direction and its speed is increasing. $a -ve$
- (C) An object moves in the negative direction and its speed is decreasing. $a +ve$
- (D) An object moves in the positive direction and its speed is constant. $a = 0$
- (E) An object moves in the negative direction and its speed is constant. $a = 0$

A8. Suppose the same net force was applied to objects A and B, where object A is twice as massive as object B. How do the accelerations of A and B compare?

C

- (A) The accelerations are the same.
- (B) The acceleration of A is twice as large.
- (C) The acceleration of B is twice as large.
- (D) The accelerations are equal and opposite.
- (E) More information is needed to answer the question.

$$\Sigma \vec{F} = m\vec{a}$$

$$\vec{a} = \frac{\Sigma \vec{F}}{m}$$

A9. A friction force is...

A

- (A) a contact force that acts parallel to the contact surfaces.
- (B) a contact force that acts perpendicular to the contact surfaces.
- (C) a scalar quantity since it can act in any direction along a surface.
- (D) always proportional to the weight of an object.
- (E) always equal to the normal force between the objects in contact.

A10. You are standing on a bathroom scale in an elevator. In which one of the following situations will the scale read the same as when the elevator is at rest?

D

- (A) The elevator is moving upward with increasing speed.
- (B) The elevator is moving upward with decreasing speed.
- (C) The elevator is moving downward with increasing speed.
- (D) The elevator is moving downward with constant speed.
- (E) The elevator is moving downward with decreasing speed.

PART B

FOR EACH OF THE FOLLOWING PROBLEMS, WORK OUT THE SOLUTION IN THE SPACE PROVIDED AND ENTER YOUR ANSWERS ON PAGE 6.

ONLY THE ANSWERS WILL BE MARKED. THE SOLUTIONS WILL NOT BE MARKED.

- B1. A train is traveling in a direction 28.7° east of north. The component of its velocity in the easterly direction has a magnitude of 4.03 m/s . Calculate the magnitude of the component of its velocity in the northerly direction.

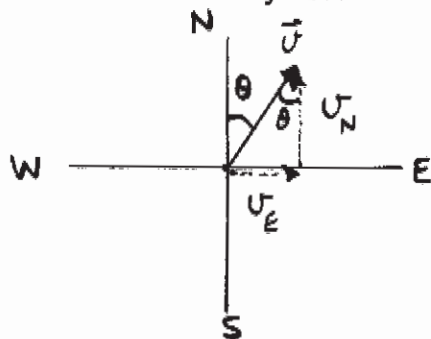

$$v_E = 4.03 \text{ m/s}$$

$$\tan \theta = \frac{v_E}{v_N}$$

$$v_N = \frac{v_E}{\tan \theta} = \frac{4.03 \text{ m/s}}{\tan(28.7^\circ)} = 7.36 \text{ m/s}$$

- B2. For the displacement versus time graph displayed below, calculate the average velocity over the time interval 3.00 to 6.00 seconds.

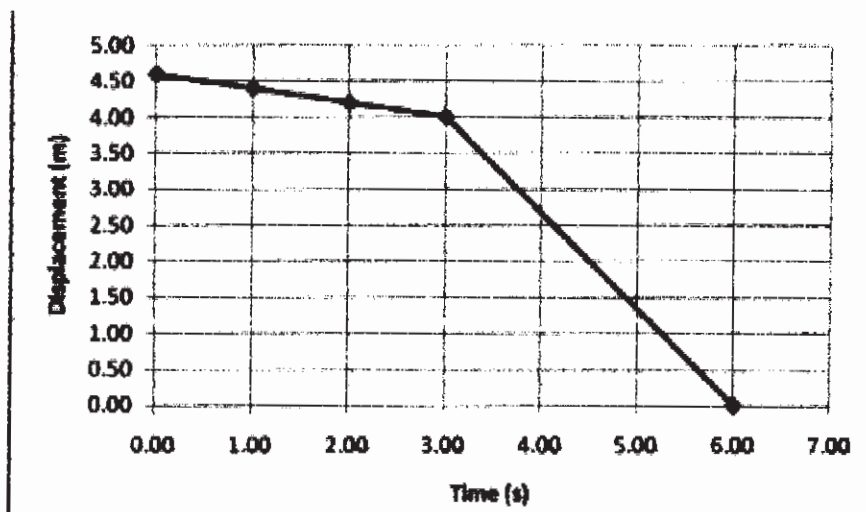

$$\bar{v} = \frac{\Delta x}{\Delta t} = \frac{x - x_0}{t - t_0} = \frac{0.00 - 4.00 \text{ m}}{6.00 \text{ s} - 3.00 \text{ s}}$$

$$\bar{v} = -1.33 \text{ m/s}$$

B3. A projectile is launched with an initial speed of 57.5 m/s at an angle of 56.8° with respect to the vertical. Calculate the maximum height reached by the projectile.

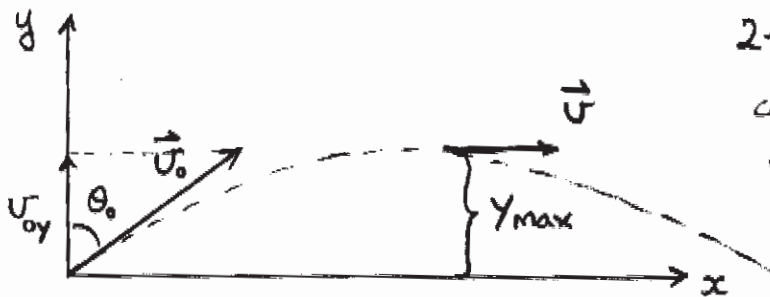

2-d motion,
constant \vec{a} in
vertical (y) dir'n.

$$v_{0y} = v_0 \cos \theta_0$$

$$v_y = 0 \text{ at } y_{\max}$$

$$a_y = -9.80 \text{ m/s}^2$$

$$\text{Use } v_y^2 = v_{0y}^2 + 2a_y y$$

$$y = \frac{v_y^2 - v_{0y}^2}{2a_y}$$

$$y_{\max} = \frac{0 - (57.5 \text{ m/s})^2 (\cos(56.8^\circ))^2}{2(-9.80 \text{ m/s}^2)} = \boxed{50.6 \text{ m}}$$

B4. A man lifts a 2.15 kg stone vertically with his hand at a constant upward acceleration of 1.46 m/s². Calculate the magnitude of the force exerted on the stone by the man's hand.

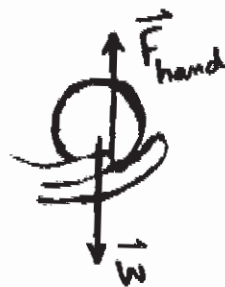

Newton II

$$\Sigma \vec{F} = m\vec{a}$$

$$F_{\text{hand}} - W = ma$$

$$F_{\text{hand}} = ma + W$$

$$F_{\text{hand}} = ma + mg = m(a+g)$$

$$F_{\text{hand}} = (2.15 \text{ kg})(1.46 \text{ m/s}^2 + 9.80 \text{ m/s}^2)$$

$$\boxed{F_{\text{hand}} = 24.2 \text{ N}}$$

continued on page 6...

B5. At what distance from the ^{centre} surface of the Earth will an object experience an acceleration due to gravity of $\frac{1}{2}g$? (Ignore the gravitational force due to all other celestial objects.)

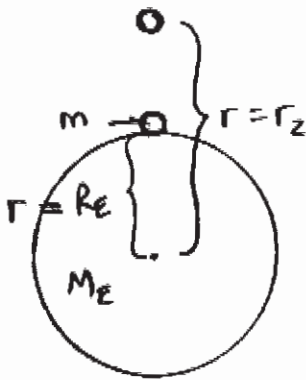

Gravitational force of Earth on object of mass m is $F_{\text{grav}} = \frac{GM_E m}{r^2}$

acceleration due to gravity is obtained by applying Newton II:

$$\frac{GM_E m}{r^2} = ma \Rightarrow a = \frac{GM_E}{r^2}. \text{ when } r = R_E, a = \frac{GM_E}{R_E^2} = g$$

Want r_2 such that $a = \frac{1}{2}g$. i.e. $\frac{GM_E}{r_2^2} = \frac{1}{2} \frac{GM_E}{R_E^2}$

$$\therefore r_2^2 = 2R_E^2 \Rightarrow r_2 = \sqrt{2}R_E = \sqrt{2}(6.38 \times 10^6 \text{ m})$$

$$r_2 = 9.02 \times 10^6 \text{ m}$$

ANSWERS FOR PART B

ENTER THE ANSWERS FOR THE PART B PROBLEMS IN THE BOXES BELOW.

THE ANSWERS MUST CONTAIN THREE SIGNIFICANT FIGURES AND THE UNITS MUST BE GIVEN.

ONLY THE ANSWERS WILL BE MARKED. THE SOLUTIONS WILL NOT BE MARKED.

B1

B2

B3

B4

B5

PART C

IN EACH OF THE FOLLOWING QUESTIONS, GIVE THE COMPLETE SOLUTION AND ENTER THE FINAL ANSWER IN THE BOX PROVIDED.

THE ANSWERS MUST CONTAIN THREE SIGNIFICANT FIGURES AND THE UNITS MUST BE GIVEN.

NO CREDIT WILL BE GIVEN FOR ANSWERS ONLY, SHOW AND EXPLAIN YOUR WORK. EQUATIONS NOT PROVIDED ON THE FORMULA SHEET MUST BE DERIVED.

C1. The fastest known land animal, the cheetah, can accelerate from rest to 20.0 m/s over a distance of 4 stride lengths. Assume that the cheetah's acceleration is constant and that its stride length is 6.60 m.

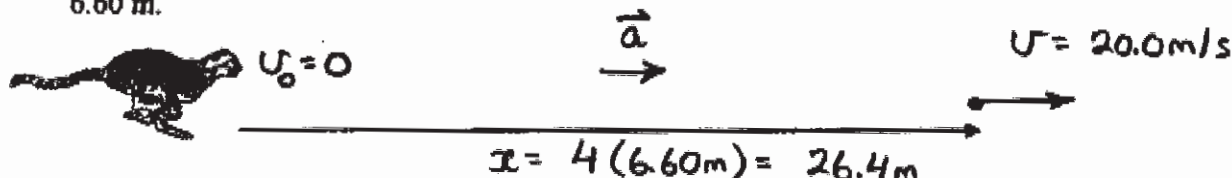

(a) Calculate the magnitude of the acceleration of the cheetah.

Use $v^2 = v_0^2 + 2ax$

7.58 m/s²

$$a = \frac{v^2 - v_0^2}{2x} = \frac{(20.0\text{m/s})^2 - 0^2}{2(26.4\text{m})}$$

$$a = 7.58 \text{ m/s}^2$$

(b) Calculate the time for the cheetah to reach 20.0 m/s.

Use $v = v_0 + at$

2.64 s

$$t = \frac{v - v_0}{a}$$

$$t = \frac{20.0\text{m/s} - 0}{7.58 \text{ m/s}^2} = 2.64 \text{ s}$$

(c) Calculate the magnitude of the cheetah's final velocity in km/h.

72.0 km/h

$$v = 20.0 \frac{\text{m}}{\text{s}} \times \frac{3600 \text{ s}}{\text{h}} \times \frac{1 \text{ km}}{1000 \text{ m}} = 72.0 \frac{\text{km}}{\text{h}}$$

C2. A physics textbook slides off a horizontal tabletop with an initial speed of 1.05 m/s. It hits the floor 0.350 s later. Calculate the displacement vector, r , of the book from the edge of the tabletop to the point where the textbook hits the floor.

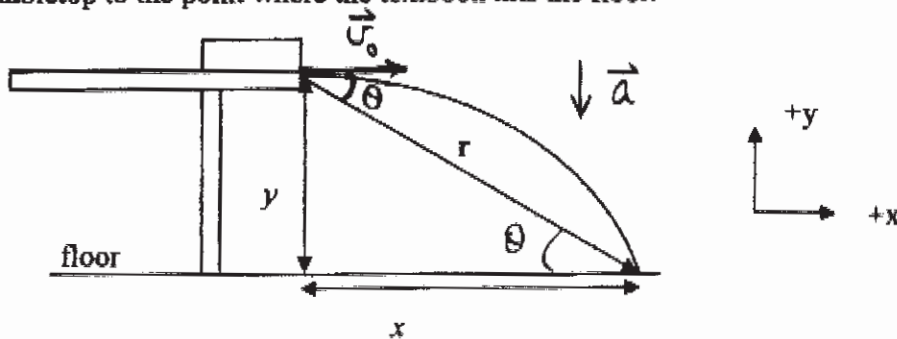

x	y
$x = ?$	$y = ?$
$u_{0x} = 1.05 \text{ m/s}$	$u_{0y} = 0$
$a_x = 0$	$a_y = -9.80 \text{ m/s}^2$
$u_x = 1.05 \text{ m/s}$	$u_y = ?$
$t = 0.350 \text{ s}$	

magnitude:	0.704 m
direction:	58.5° below the horizontal

Since $a_x = 0$, $x = u_{0x} t = (1.05 \text{ m/s})(0.350 \text{ s}) = 0.368 \text{ m}$

Since $u_{0y} = 0$, $y = \frac{1}{2} a_y t^2 = \frac{1}{2} (-9.80 \text{ m/s}^2)(0.350 \text{ s})^2 = 0.600 \text{ m}$

$\therefore r = \sqrt{x^2 + y^2} = 0.704 \text{ m}$

From diagram, $\theta = \text{invtan} \left(\frac{y}{x} \right) = 58.5^\circ$

C3. A playground slide (an inclined plane) of length L is at an angle θ with the horizontal. A child of mass m starts from rest at the top of the slide. The child's speed at the bottom of the slide is exactly half of what it would have been if the slide had been frictionless.

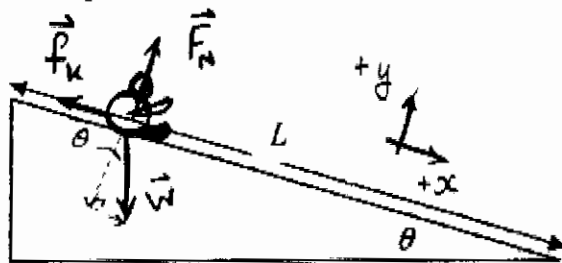

Show all forces.

Note that: $\Sigma F_x = ma$ and $\Sigma F_y = 0$
 and $v_0 = 0$

Let v_{friction} = speed at bottom with friction

$v_{\text{frictionless}}$ = speed at bottom if no friction

(a) Determine the ratio c , where $c = \frac{a_{\text{friction}}}{a_{\text{frictionless}}}$. (a_{friction} is the child's acceleration when friction is present; $a_{\text{frictionless}}$ is the child's acceleration if the slide had been frictionless.)

From kinematics, $v^2 = v_0^2 + 2ax = 2ax$ since $v_0 = 0$

$\therefore v_{\text{friction}}^2 = 2a_{\text{friction}}L$

$c = \frac{1}{4}$

and $v_{\text{frictionless}}^2 = 2a_{\text{frictionless}}L$

$\therefore \frac{a_{\text{friction}}}{a_{\text{frictionless}}} = \frac{v_{\text{friction}}^2}{v_{\text{frictionless}}^2} = \frac{(\frac{1}{2}v_{\text{frictionless}})^2}{(v_{\text{frictionless}})^2} = \frac{1}{4}$

(b) Derive an expression, in terms of θ , for the coefficient of kinetic friction between the child and the slide.

Since $f_k = \mu_k F_N$, $\mu_k = \frac{f_k}{F_N}$

$\mu_k = \frac{3}{4} \tan \theta$

Determine f_k from $\Sigma F_x = ma_{\text{friction}}$;

$W_x - f_k = ma_{\text{friction}}$

$mg \sin \theta - f_k = ma_{\text{friction}}$

$f_k = mg \sin \theta - ma_{\text{friction}}$

Determine F_N from $\Sigma F_y = 0$

$F_N - W_y = 0 \Rightarrow F_N = W_y$

so $F_N = mg \cos \theta$

$\therefore \mu_k = \frac{mg \sin \theta - ma_{\text{friction}}}{mg \cos \theta}$ ①

Now consider frictionless situation:

$\Sigma F_x = ma_{\text{frictionless}}$

$W_x = ma_{\text{frictionless}}$

$mg \sin \theta = ma_{\text{frictionless}}$

and since $a_{\text{friction}} = \frac{1}{4} a_{\text{frictionless}}$,

$a_{\text{friction}} = \frac{1}{4} g \sin \theta$

\therefore substitution into ① yields $\mu_k = \frac{g \sin \theta - \frac{1}{4} g \sin \theta}{g \cos \theta}$

so $\mu_k = \frac{3}{4} \frac{\sin \theta}{\cos \theta} = \frac{3}{4} \tan \theta$

END OF EXAMINATION